

**INVERTER MULTI
AIR CONDITIONER
DUCT type**

**SERVICE
MANUAL**



Models

Indoor unit		Outdoor unit
ARY9LUAB	}	AOY18LMAK2
ARY12LUAD		
ARY14LUAD		

CONTENTS

SPECIFICATIONS	1
OUTLINE AND DIMENSIONS	2
REFRIGERANT SYSTEM DIAGRAM	5
CIRCUIT DIAGRAM	6
INDOOR PCB CIRCUIT DIAGRAM	8
OUTDOOR PCB CIRCUIT DIAGRAM	9
ERROR CONTENTS	10
DISASSEMBLY ILLUSTRATION	11
PARTS LIST	20



Большая библиотека технической документации

<https://splitsystema48.ru/instrukcii-po-ekspluatatsii-kondicionerov.html>

каталоги, инструкции, сервисные мануалы, схемы.

SPECIFICATIONS

TYPE	COOL & HEAT		
INDOOR UNIT	ARY9LUAB	ARY12LUAD	ARY14LUAD
OUTDOOR UNIT	AOY18LMAK2		

ELECTRICAL DATA (INDOOR UNIT)

COOLING CAPACITY	(kW)	2.6	3.5	4.3
HEATING CAPACITY	(kW)	3.1	4.0	4.9
MOISTURE REMOVAL	(ℓ /hr)	1.0	1.2	1.5
AIR CIRCULATION-Hi	(m ³ /hr)	450	600	800

ELECTRICAL DATA (OUTDOOR UNIT)

POWER SOURCE	(V)	230		
FREQUENCY	(Hz)	50		
COOLING CAPACITY (MAX)	(kW)	5.5 (6.5)		
HEATING CAPACITY (MAX)	(kW)	6.4 (7.1)		
RUNNING CURRENT (MAX)	(A)	COOLING	7.5 (9.7)	
		HEATING	8.0 (9.7)	
INPUT WATTS (MAX)	(kW)	COOLING	1.73 (2.22)	
		HEATING	1.84 (2.22)	
E.E.R.	(kW / kW)	COOLING	3.18	
		HEATING	3.48	

COMPRESSOR

TYPE	Hermetic type, Inverter, 4 poles, Three phase, DC motor, Rotary		
DISCRIMINATION	TNB 220 FPCM		
REFRIGERANT	R410A	(g)	1,900

FAN MOTOR

POWER SOURCE	(V)	230			
INDOOR UNIT	DISCRIMINATION	MFA-9NTAT	MFA-18NTT	MFA-18NTT	
	HI	(r.p.m.)	955	750	1,000
	MED	(r.p.m.)	870	680	860
	LO	(r.p.m.)	800	610	720
OUTDOOR UNIT	(r.p.m.)	780			

DIMENSIONS

INDOOR UNIT	H x W x D	(mm)	217 x 663 x 595	217 x 953 x 595
OUTDOOR UNIT	H x W x D	(mm)	650 x 830 x 320	

WEIGHT

INDOOR UNIT	GROSS / NET	(kg)	22 / 18	29 / 25
OUTDOOR UNIT	GROSS / NET	(kg)	62 / 56	

NOISE LEVEL

INDOOR UNIT	HI	(dB)	39	33	40
	MED	(dB)	37	30	35
	LO	(dB)	34	27	30
OUTDOOR UNIT	COOLING	(dB)	49		
	HEATING	(dB)	50		

OUTLINE AND DIMENSIONS

(unit : mm)

INDOOR UNIT

Model : ARY9LUAB

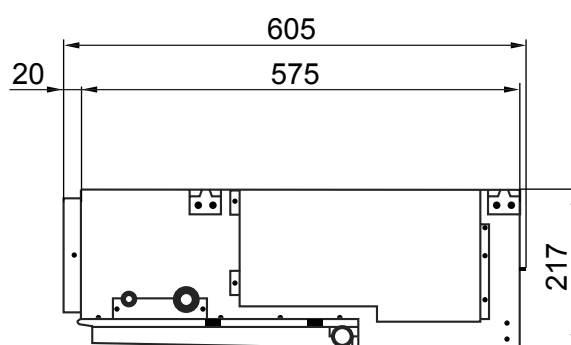
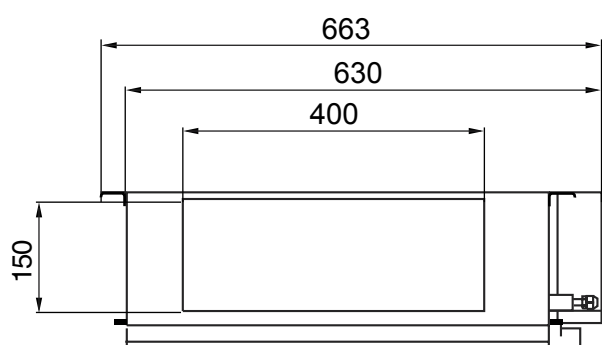
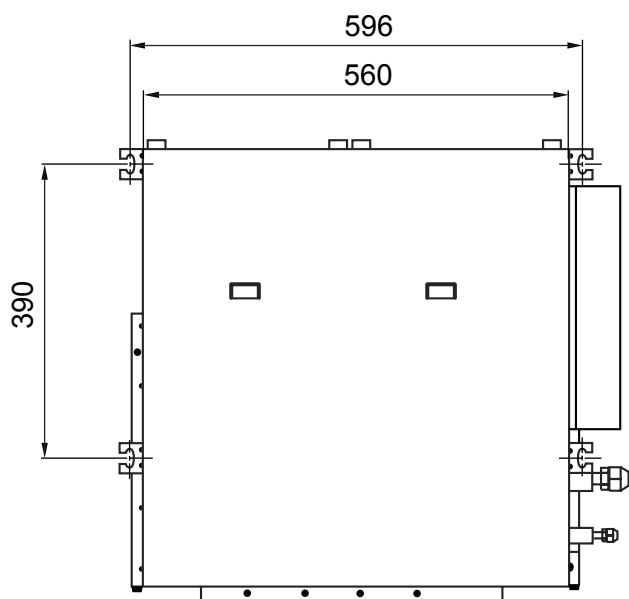

**Models : ARY12LUAD
ARY14LUAD**

Unit : mm

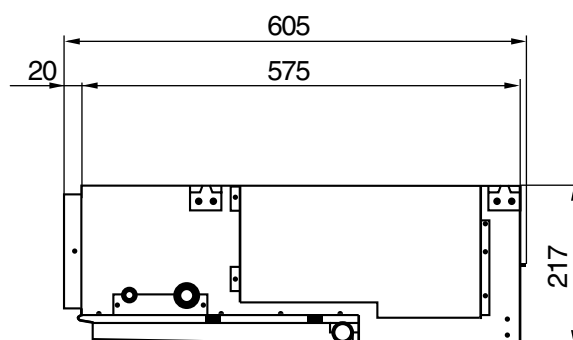
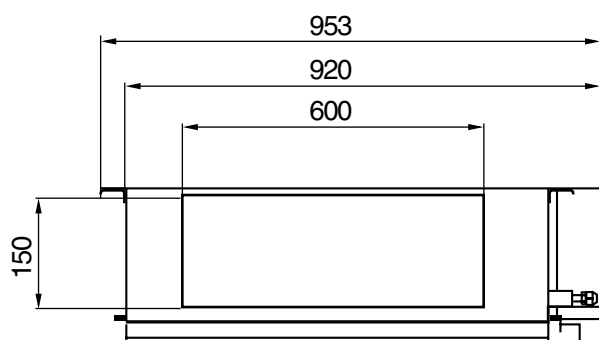
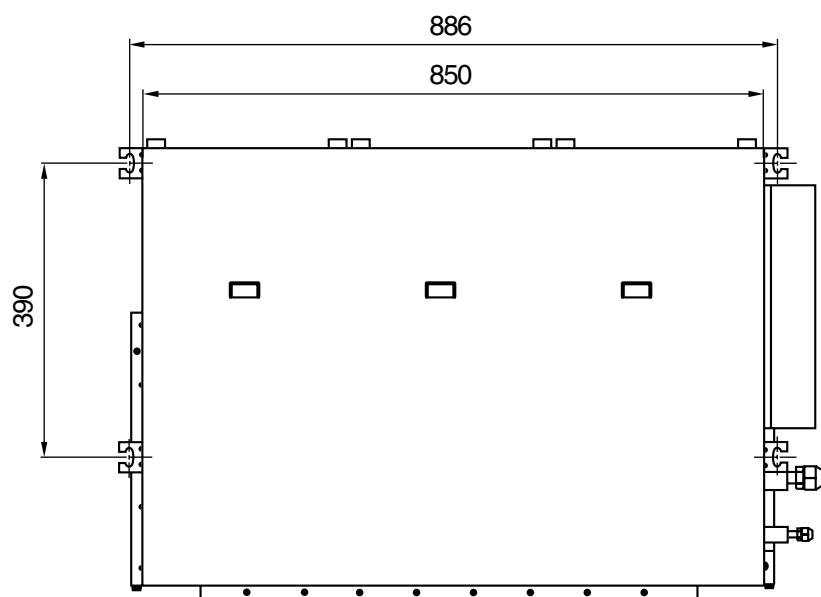

OUTDOOR UNIT

Unit : mm

Model : AOY18LMAK2

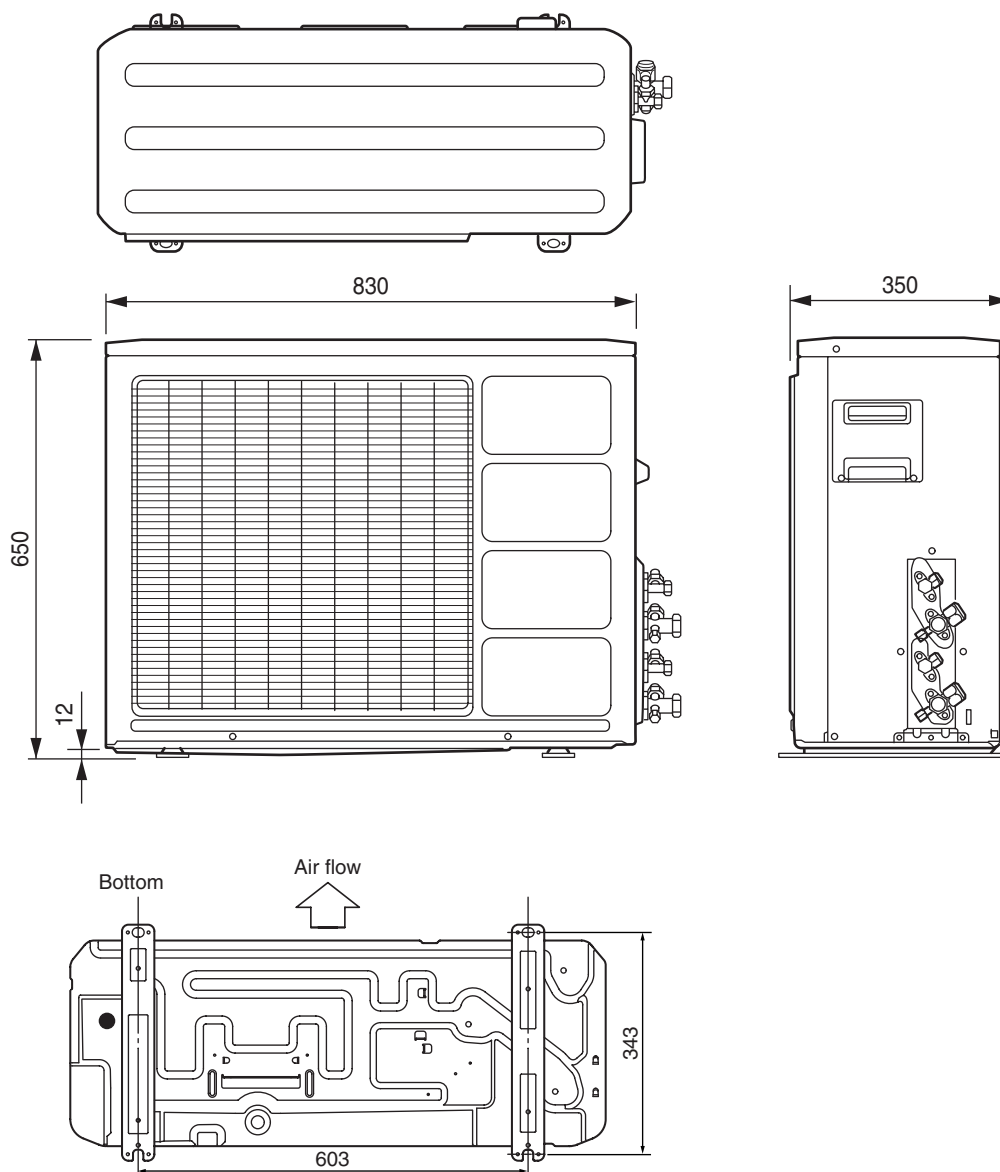

REFRIGERANT SYSTEM DIAGRAM

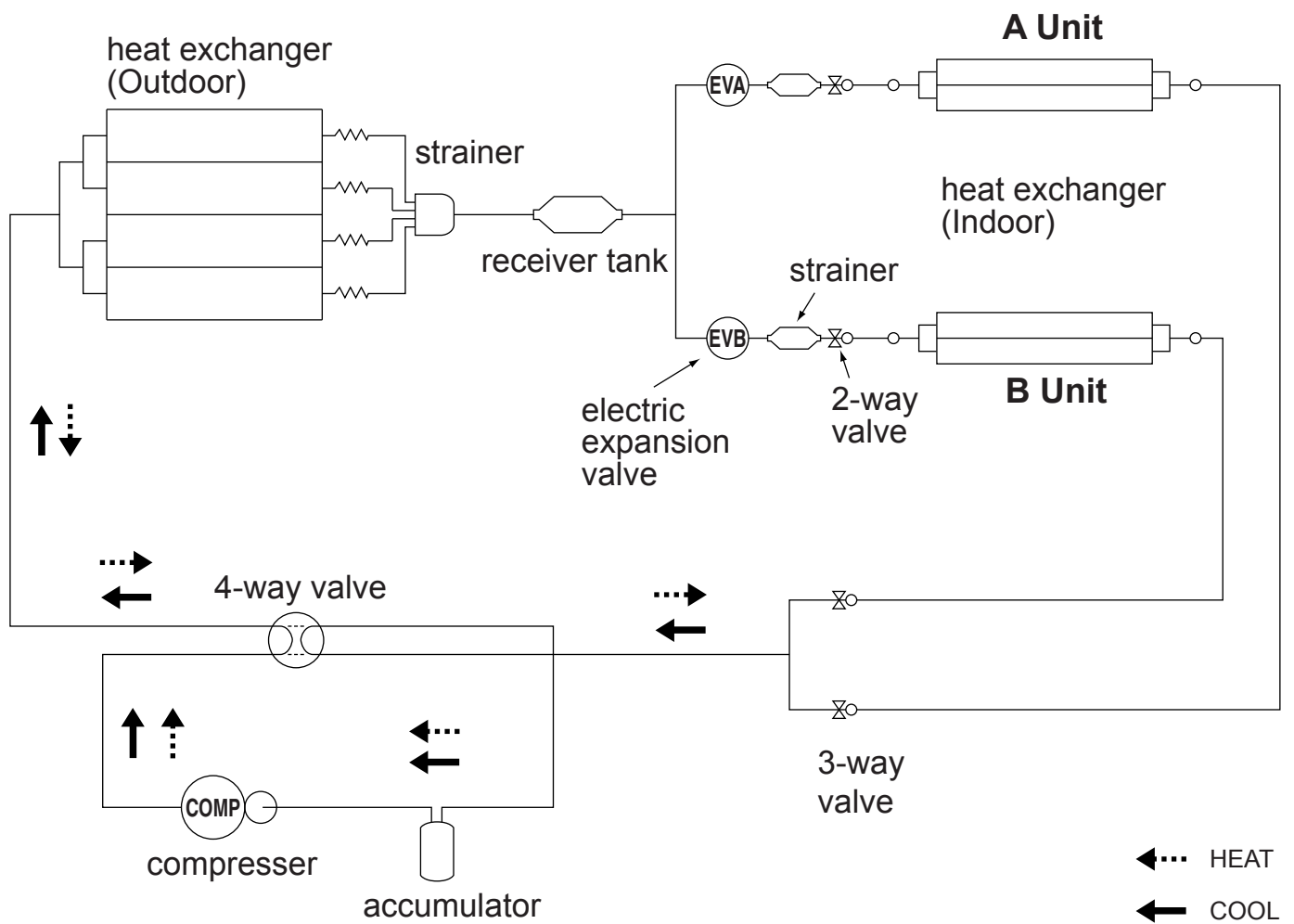

CIRCUIT DIAGRAM

INDOOR UNIT

Models :
ARY9LUAB
ARY12LUAD
ARY14LUAD

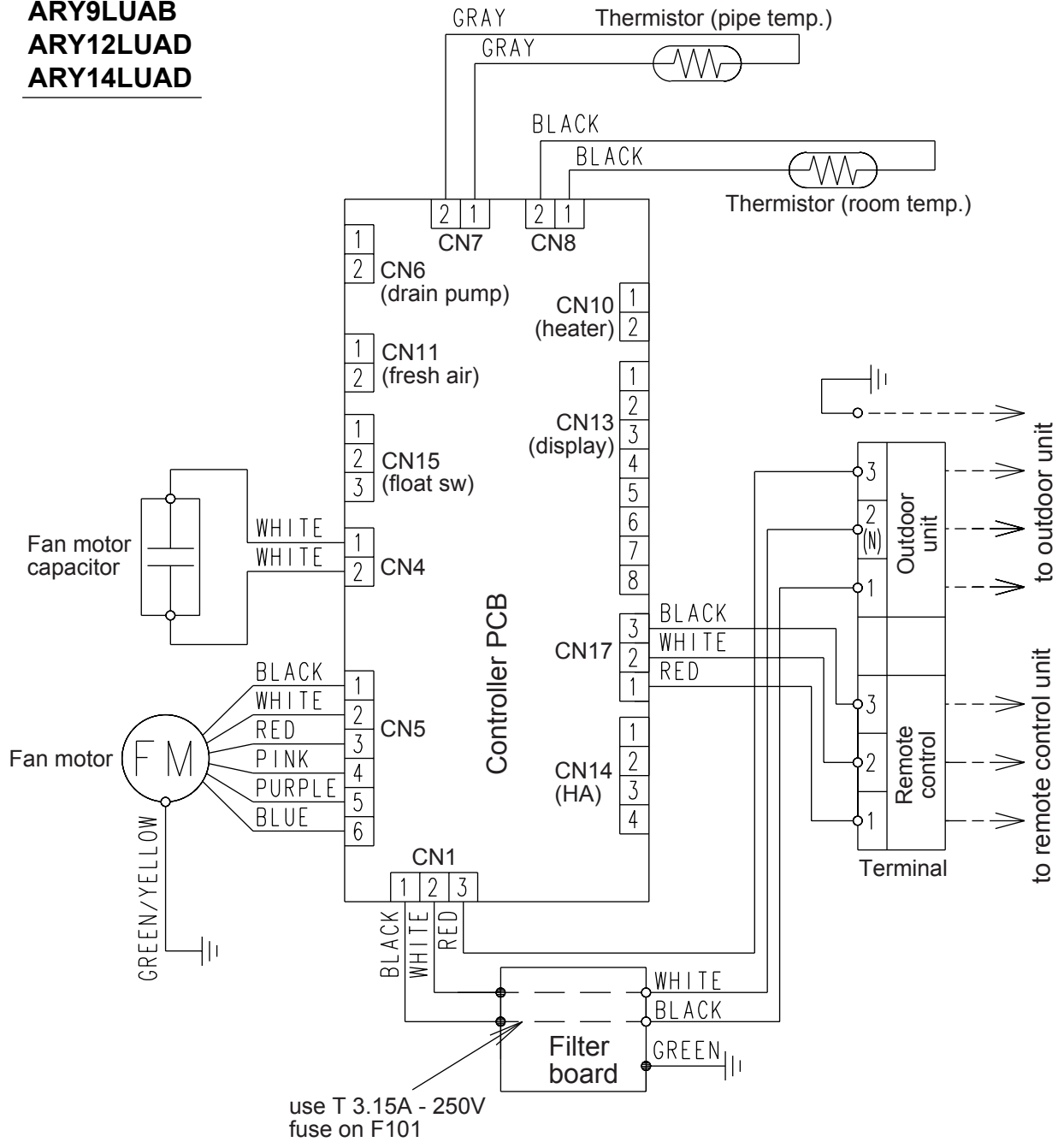

OUTDOOR UNIT

Model : AOY18LMAK2

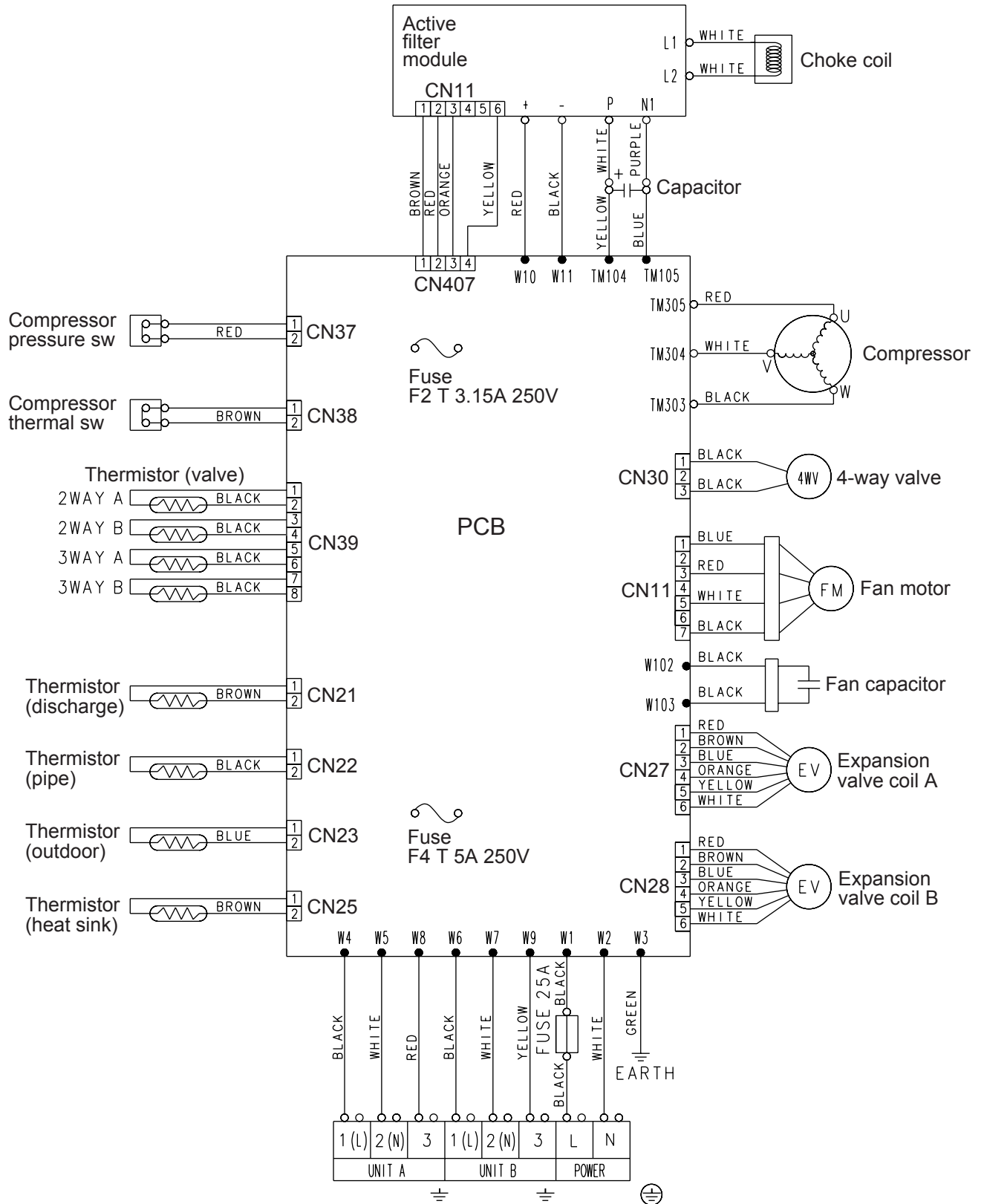

INDOOR PCB CIRCUIT DIAGRAM

Models : ARY9LUAB
ARY12LUAD
ARY14LUAD

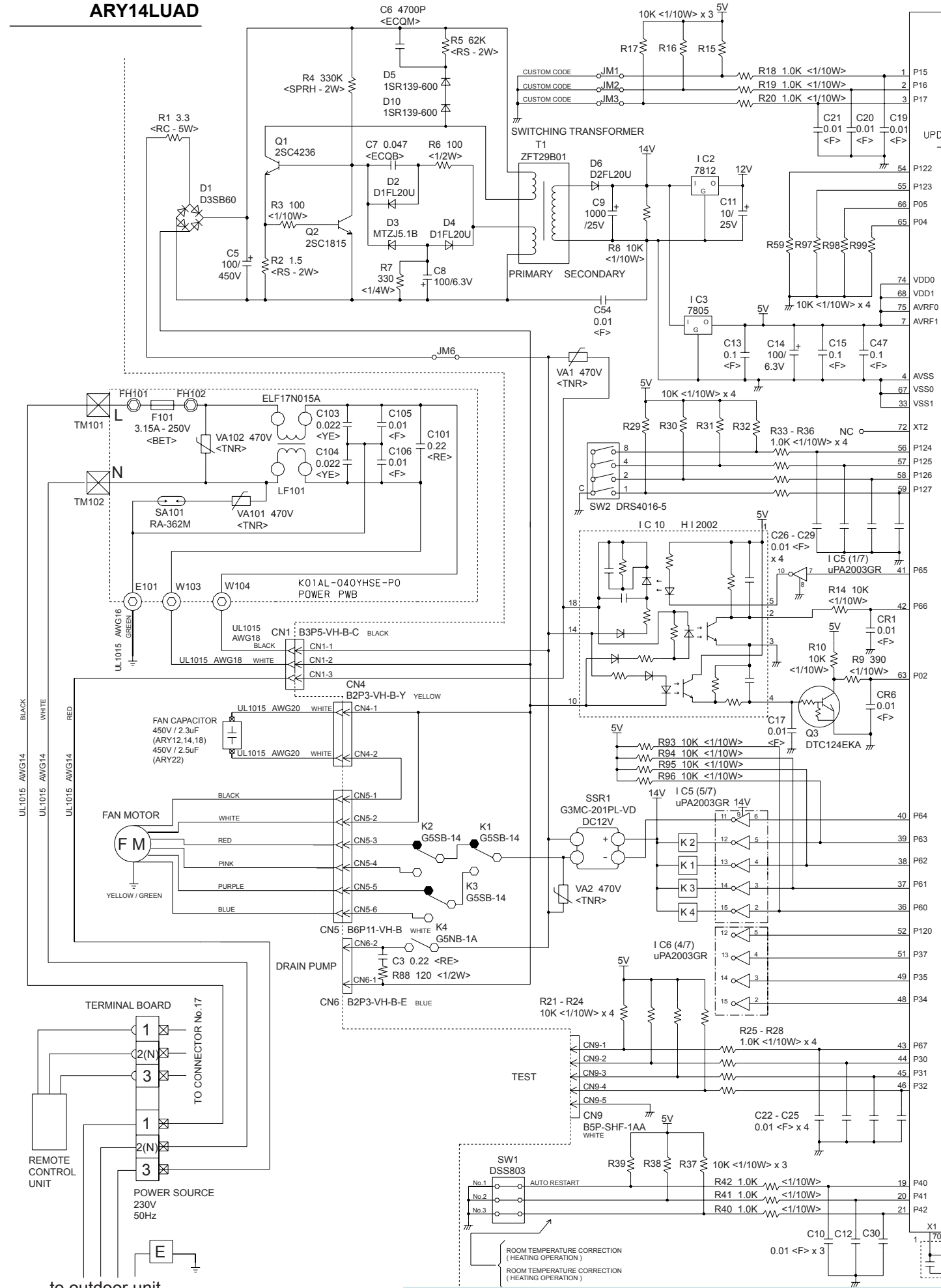

CONTROLLER PCB ASSY (main PCB)

ARY9LUAB : K01AL-0413HES-C1
ARY12LUAD : K01AL-0412HSE-C1
ARY14LUAD : K01AL-0411HSE-C1

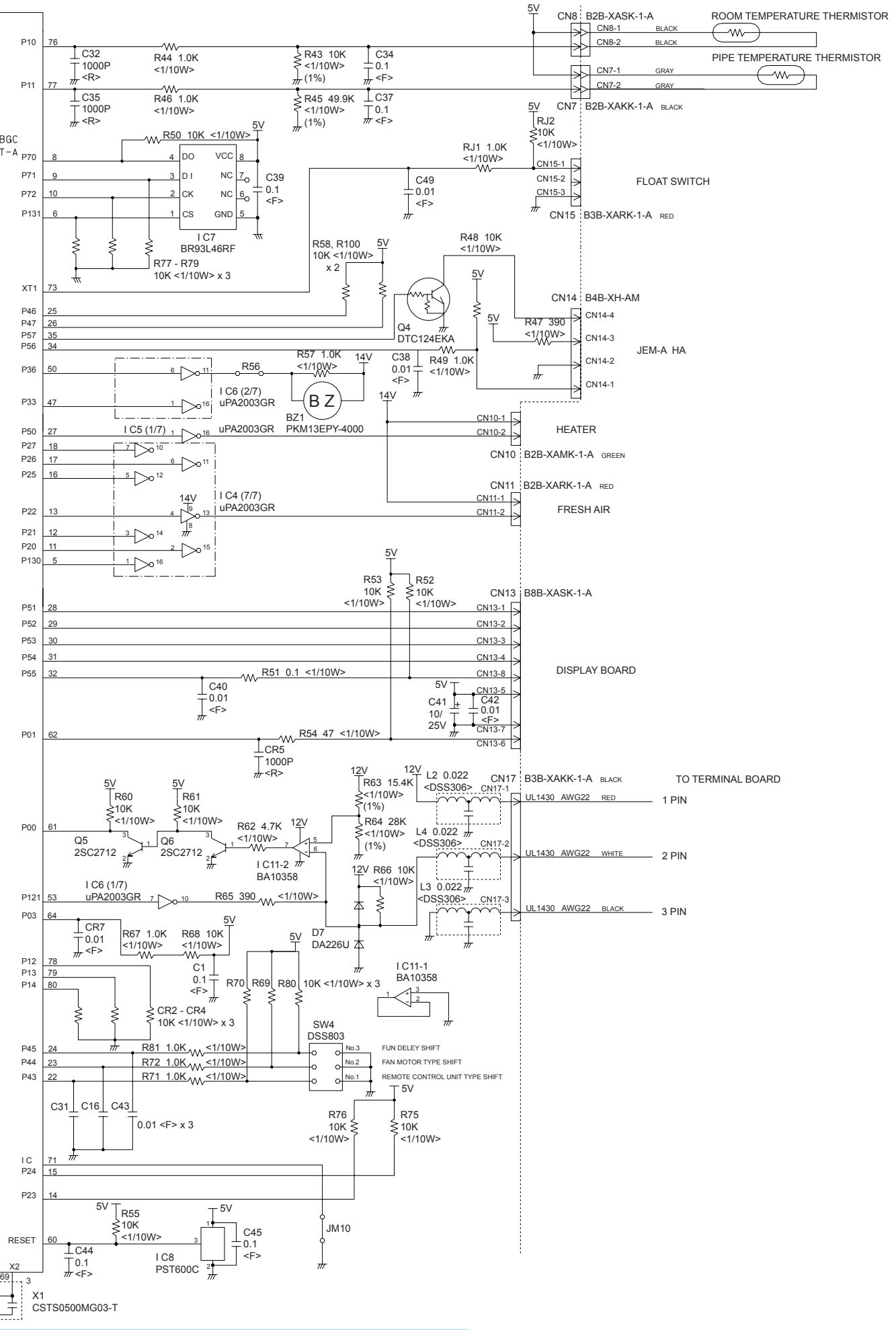

ERROR CONTENTS

INDOOR UNIT

- (1) Stop the air conditioner operation.
- (2) Press the master control button and the fan control button simultaneously for 2 seconds or more to start the test run.

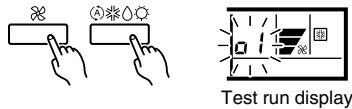

- (3) Press the start/stop button to stop the test run.

[SELF-DIAGNOSIS]

When the error indication "E:EE" is displayed, follow the following items to perform the self-diagnosis. "E:EE" indicates an error has occurred.

1. REMOTE CONTROLLER DISPLAY

- (1) Stop the air conditioner operation.
- (2) Press the set temperature buttons \wedge / \vee simultaneously for 5 seconds or more to start the self-diagnosis. Refer to the following tables for the description of each error code.

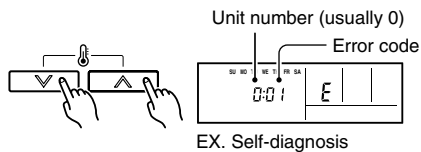

- (3) Press the set temperature buttons \wedge / \vee simultaneously for 5 seconds or more to stop the self-diagnosis.

Error code	Error contents
00	Communication error (indoor unit \longleftrightarrow remote controller)
01	Communication error (outdoor unit \rightarrow indoor unit)
02	Room temperature sensor open
03	Room temperature sensor short-circuited
04	Indoor heat exchanger temperature sensor open
05	Indoor heat exchanger temperature sensor short-circuited
06	Outdoor heat exchanger temperature sensor
08	Power source connection error
09	Float switch operated
0A	Outdoor temperature sensor
0c	Discharge pipe temperature sensor
11	Model abnormal
12	Indoor fan abnormal
13	Outdoor signal abnormal
14	Outdoor EEPROM abnormal
15	Compressor temperature sensor
16	Pressure switch abnormal
17	IPM error
1A	Compressor cannot operate
1b	Outdoor fan abnormal

DISASSEMBLY ILLUSTRATION

Model : ARY9LUAB

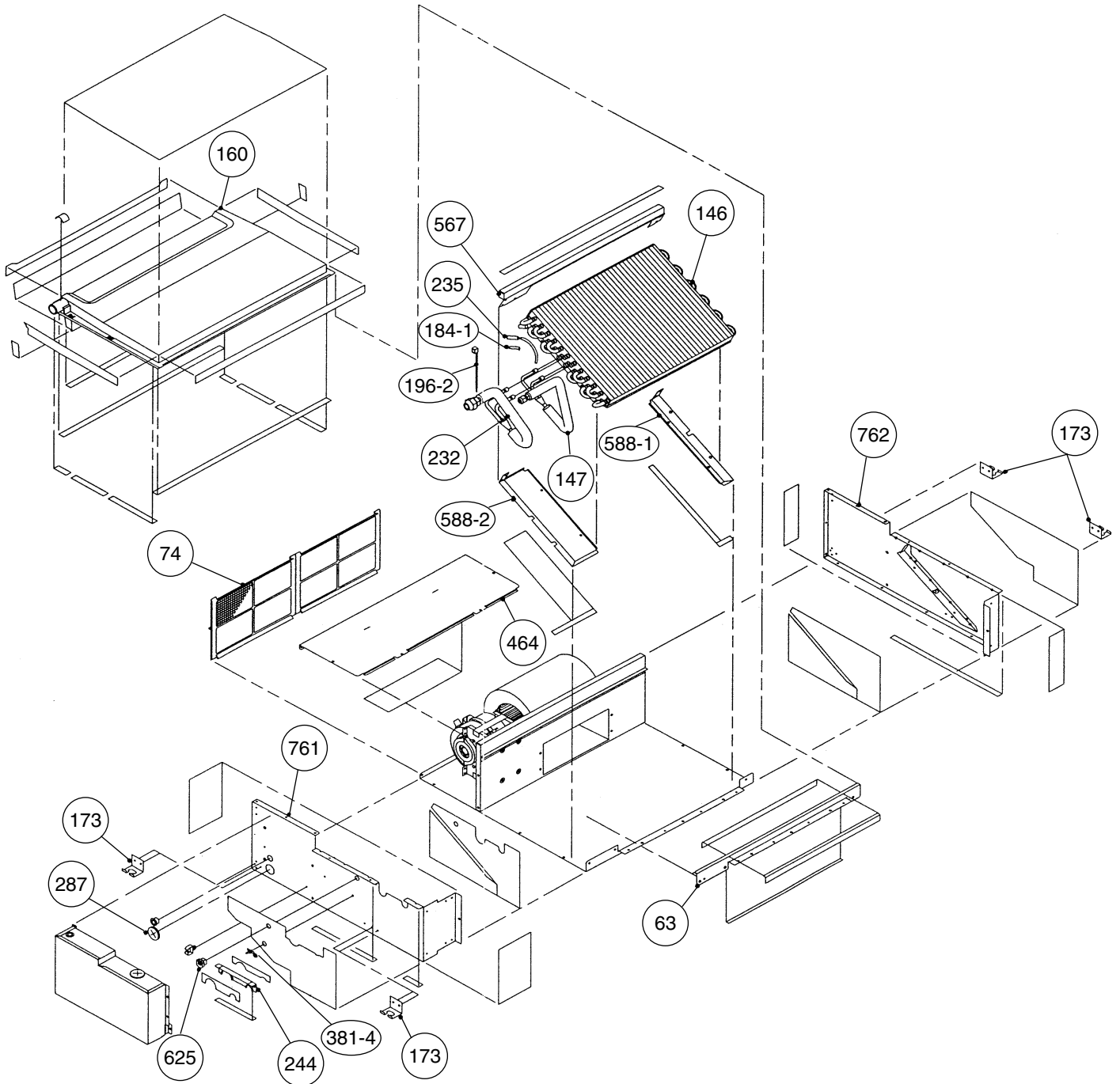

Model : ARY9LUAB

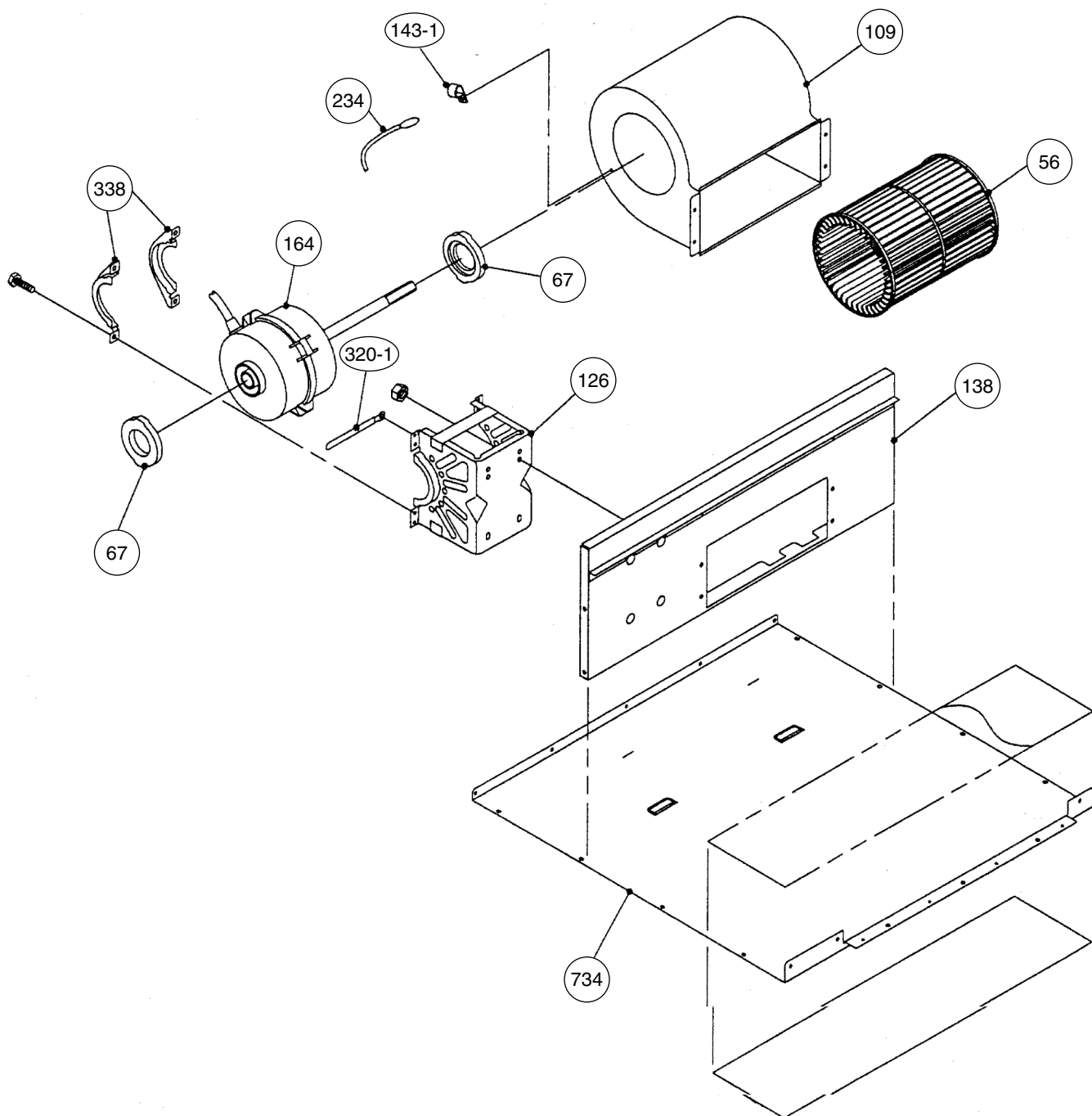

Models :
ARY12LUAD
ARY14LUAD

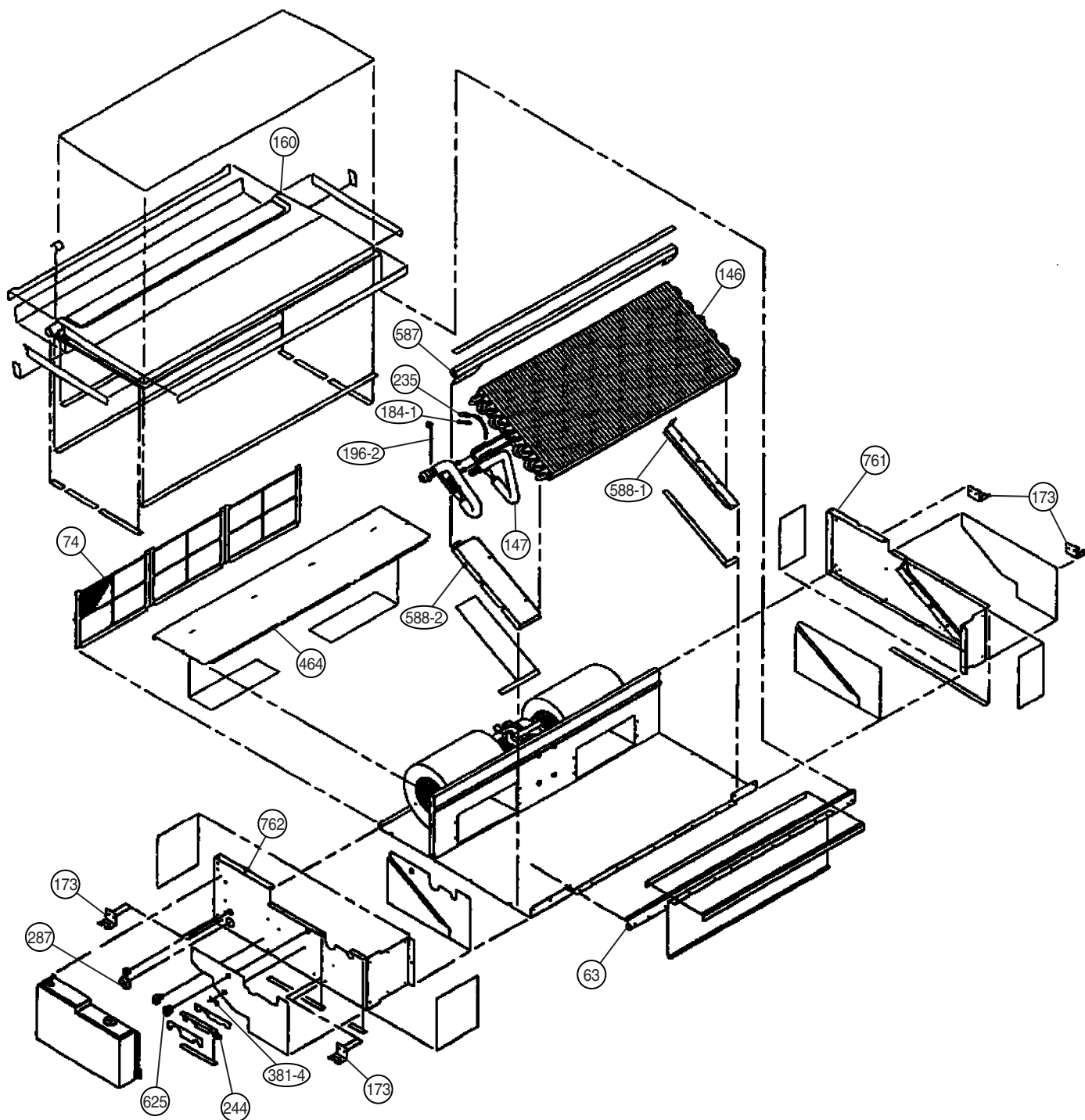

Models:
ARY12LUAD
ARY14LUAD

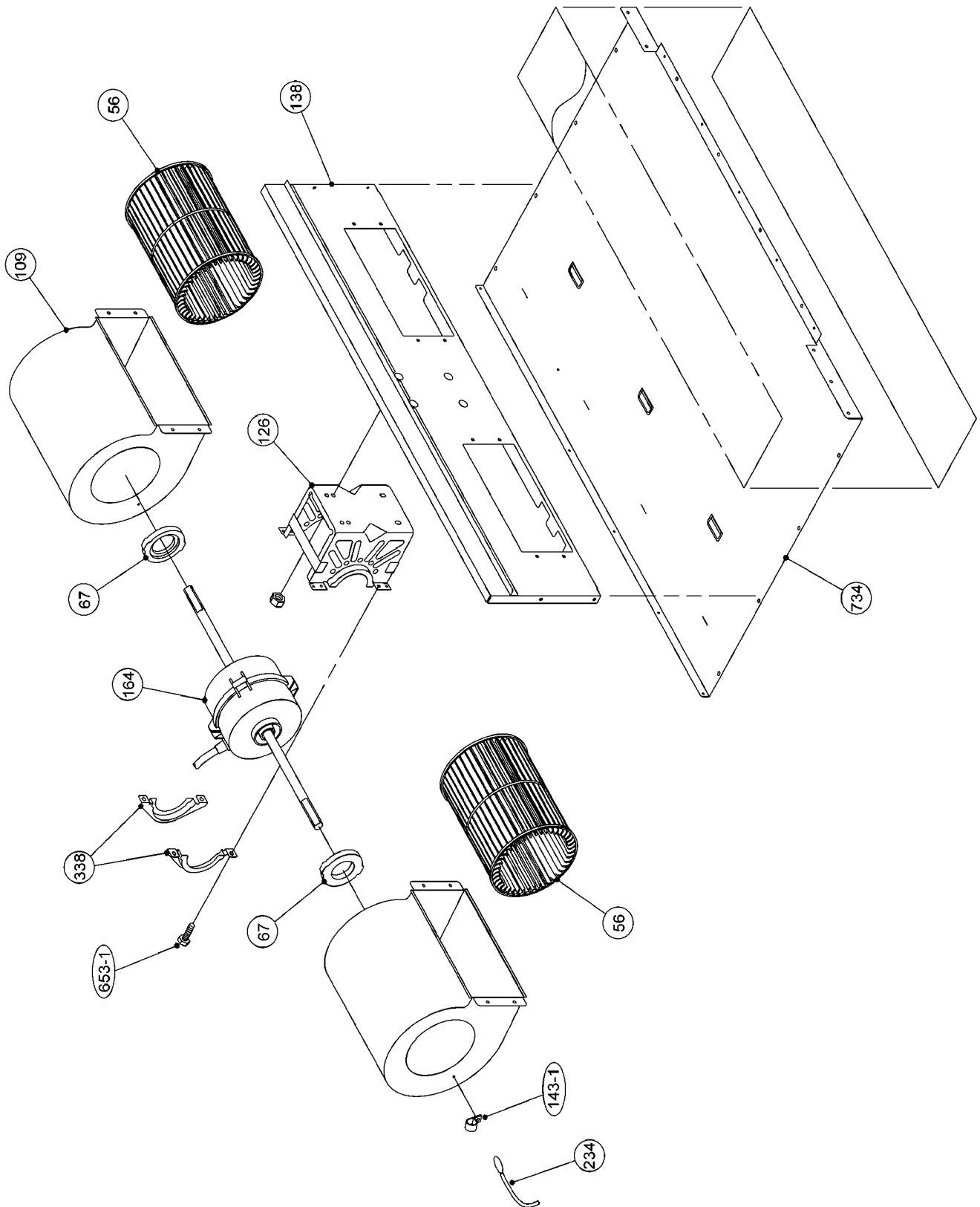

Models :
ARY9LUAB
ARY12LUAD
ARY14LUAD

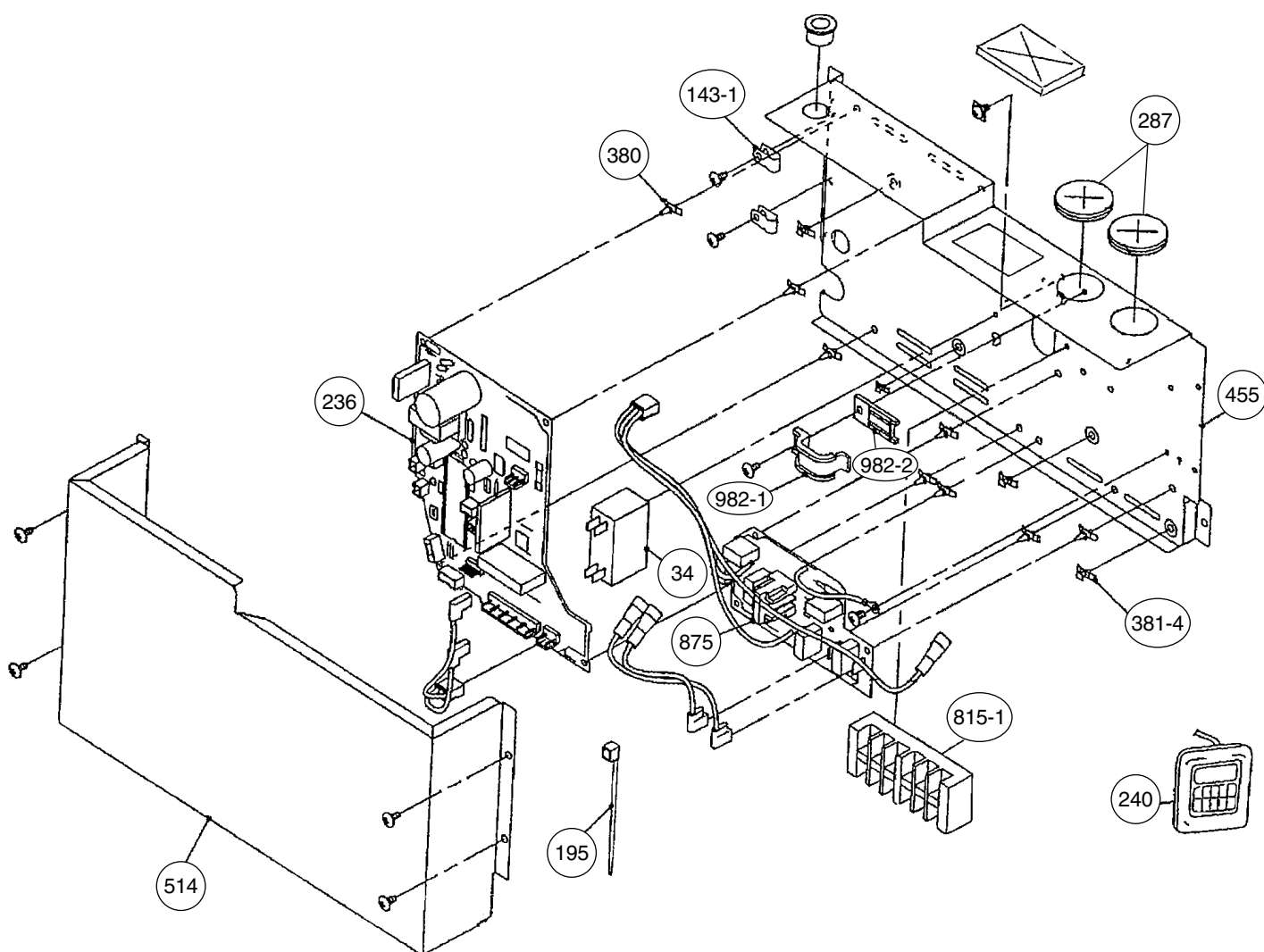

Model : AOY18LMAK2

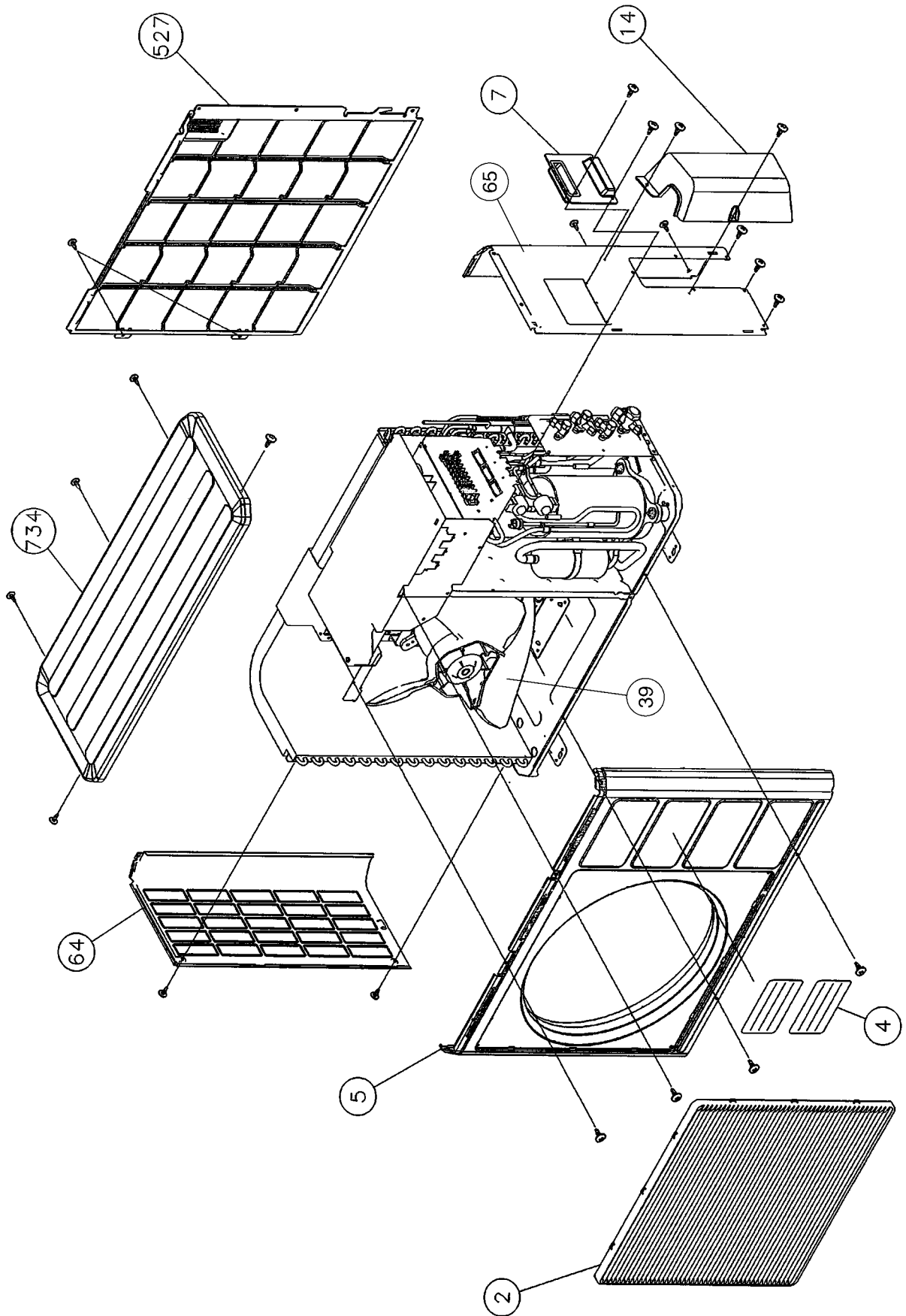

Model : AOY18LMAK2

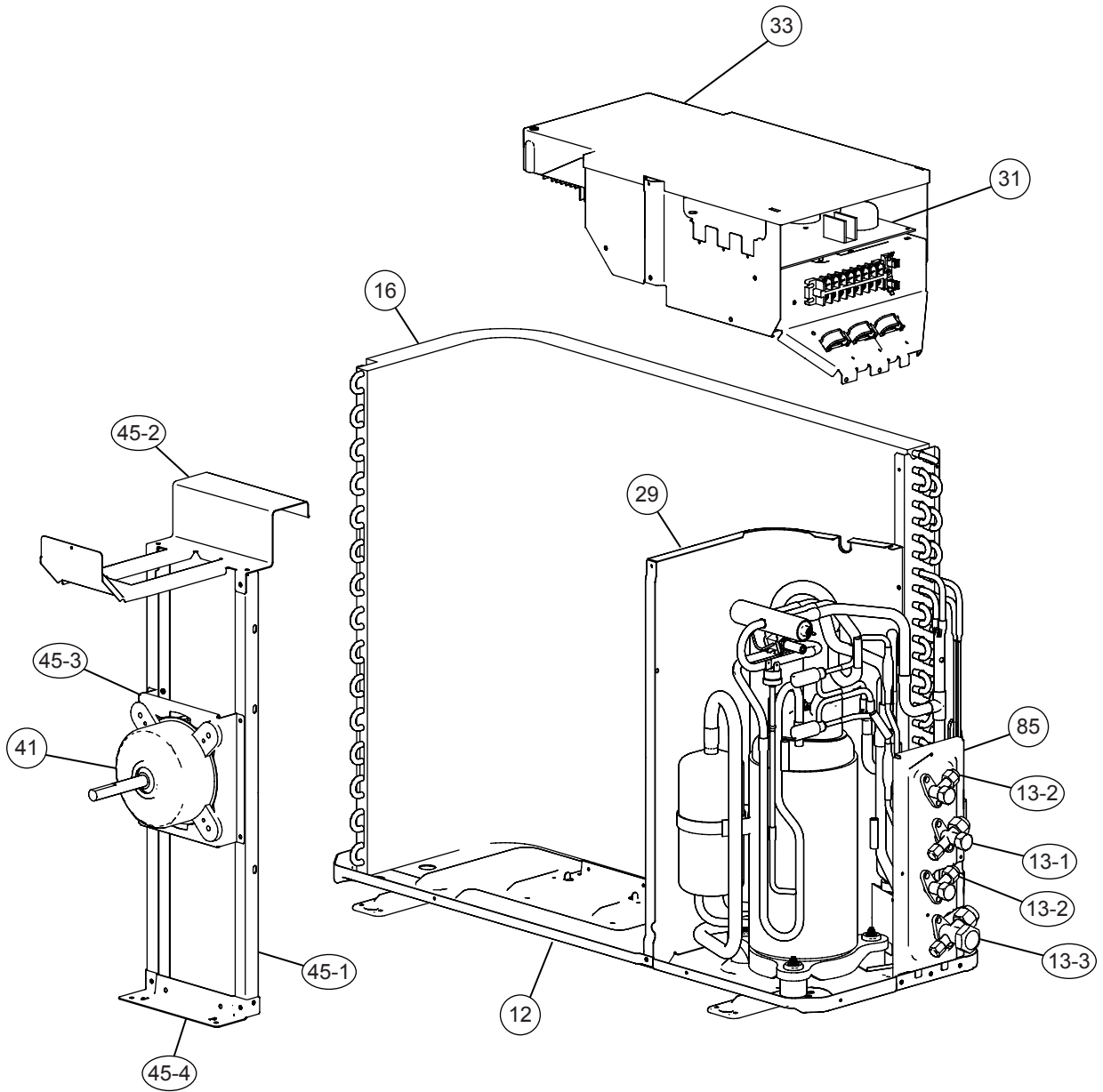

Model : AOY18LMAK2

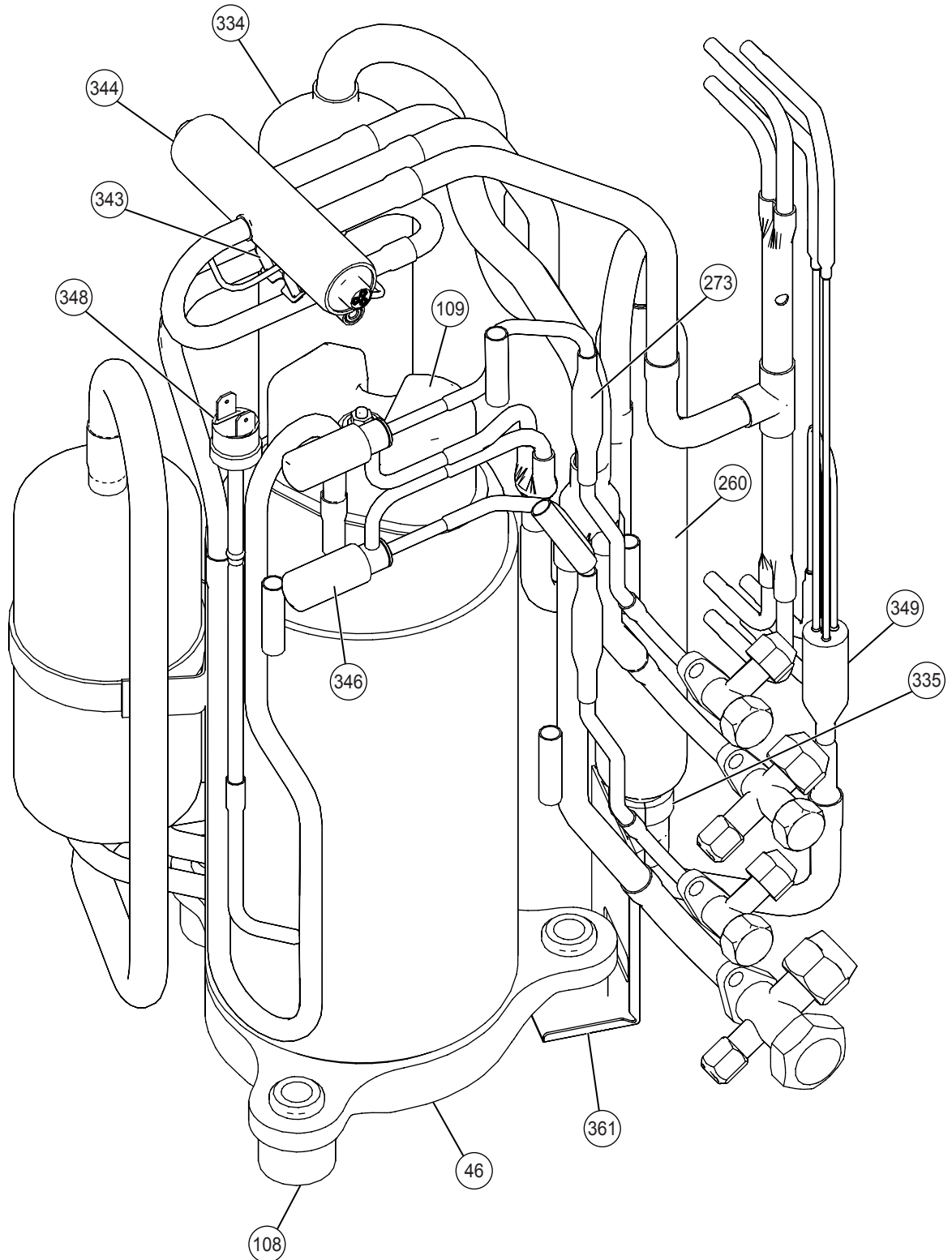

Model : AOY18LMAK2

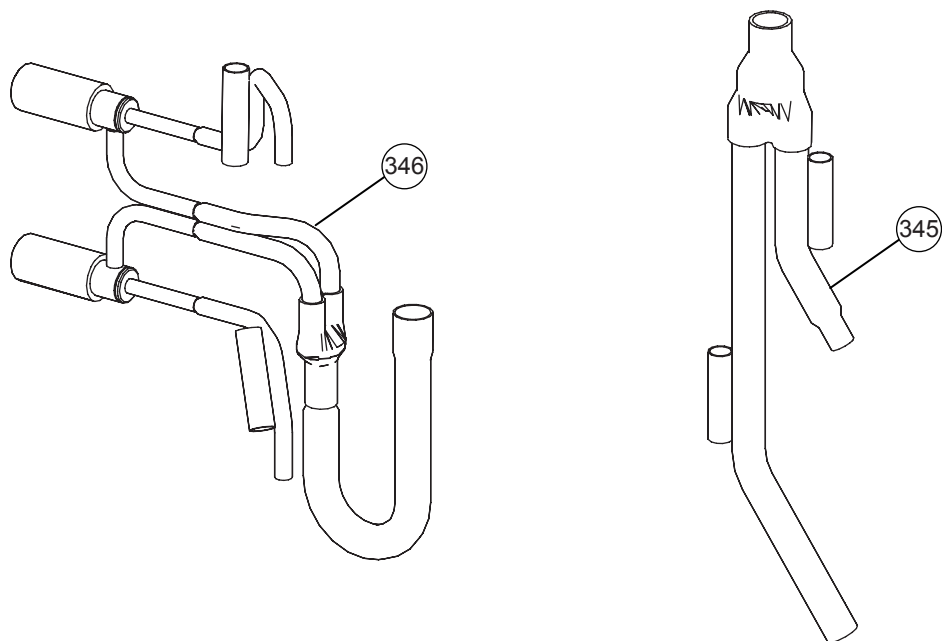
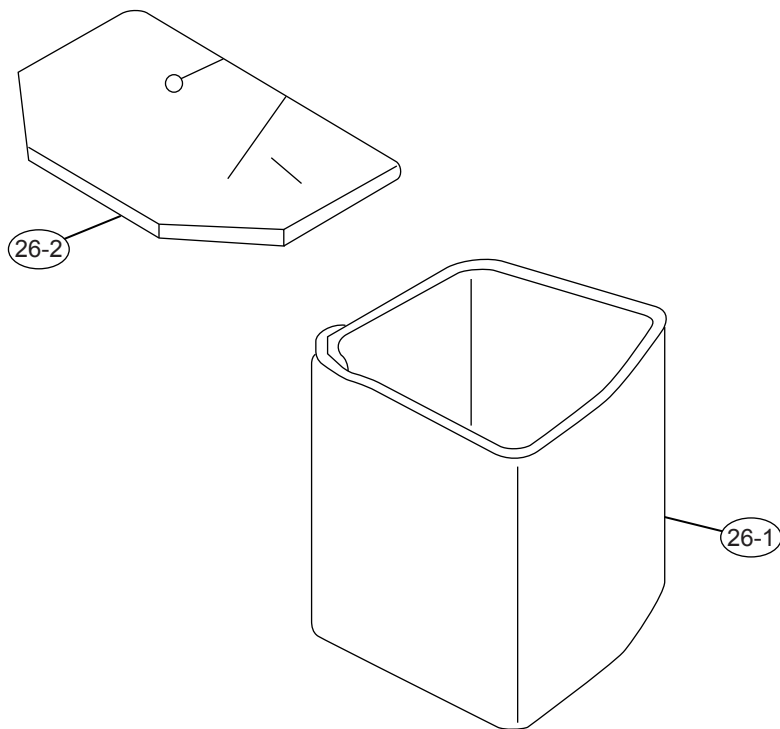

PARTS LIST

INDOOR UNIT

Ref. No.	Description	Part No.	Ord. Q'ty
		ARY9LUAB	
34	Fan Capacitor (2.5MF 450V)	9900270186	
56	Sirocco Fan Assy	9358621004	
63	Panel Assy Front	9363722000	
67	Rubber (Vibration-proof)	313659068604	
74	Air Filter	9366833017	
109	Casing Assy	9363322002	
126	Bracket (Motor) Assy	9358591000	
138	Panel Assy (Motor)	9363193008	
143-1	Clamp NK-3N	313361274700	
146	Evaporator Assy	9373255031	
147	Distributor Assy	9373034070	
160	Drain Pan Sub Assy	9364502014	
164	Motor, Induction (MFA-09NTAT)	9600778203	
173	Hook Metal	9363195002	
184-1	Thermostat Spring-A	313728262708	
195	Binder-C (SKB-100)	313361275805	
196-2	Binder-M (SKB-150)	313035356905	
232	Coupling Pipe Assy	9373038078	
234	Thermistor (Room)	9703299063	
235	Pipe Thermistor	9703297090	
236	Controller PCB Assy	9704557995 (K01AL-0413HSE-C1)	
240	Remote Control Unit (AR-3TA1)	9372266014	
244	Cover (Piping)	9363330007	
287	Cap (Power)	9352173011	
320-1	Wire Clamp Metal	313483219905	
338	Bracket (Motor)	9358594001	
380	Locking Spacer KGLS-6S	313209391403	
381-4	Spacer KGPS-6S	0600118075	
455	Control Box	9366299004	
464	Cabinet Cover Sub Assy	9364503011	
514	Control Box Cover	9363201000	
567	Support Plate (Eva.)	9363323009	
588-1	Bracket Eva. R	9363199000	
588-2	Bracket Eva. L	9363198003	
625	Cord Bush	9359240006	
734	Top Panel Sub Assy	9364507019	
761	Side Panel Right Sub Assy	9364505015	
762	Side Panel Left Sub Assy	9364506012	
815-1	Terminal 7P	9703403019	
875	Filter PCB Assy	9704561251	
982-1	Clamp (Cord)	9356857009	
982-2	Clamp (Cord)-B	9356858006	

INDOOR UNIT

Ref. No.	Description	Part No.		Ord. Q'ty
		ARY12LUAD	ARY14LUAD	
34	Capacitor (Fan Motor)	9900270179	9900270179	
56	Sirocco Fan Assy	9358621004	9358621004	
63	Front Panel Assy	9363723007	9363723007	
67	Rubber (Vibration - proof)	313659068604	313659068604	
74	Air Filter	9366833017	9366833017	
109	Casing Assy	9363322002	9363322002	
126	Motor Fixing Table Assy	9358591000	9358591000	
138	Panel Assy (Motor)	9363401004	9363401004	
143-1	Clamp NK-3N	313361274700	313361274700	
146	Evaporator Assy	9373255024	9373255024	
147	Inlet Pipe (Eva.) Assy	9373034063	9373034063	
160	Drain Pan Assy	9364502021	9364502021	
164	Fan Motor Assy (MFA-18NTT)	9600778210	9600778210	
173	Hook Metal	9363195002	9363195002	
184-1	Thermo. Spring-A	313728262708	313728262708	
195	Clamp SKB-100	313361275805	313361275805	
196-2	Clamp SKB-150	313035356905	313035356905	
234	Thermistor Assy-Room	9703299018	9703299018	
235	Thermistor Assy-Pipe	9703297090	9703297090	
236	Controller PCB Assy	9704557988 (K01AL-0412HSE-C1)	9704557971 (K01AL-0411HSE-C1)	
240	Remote Control Unit	9372266014	9372266014	
244	Cover (Piping)	9363327007	9363327007	
287	Cap (Power)	9352173011	9352173011	
338	Motor Fixture	9358594001	9358594001	
380	Locking Spacer	313209391403	313209391403	
381-4	Spacer	0600118075	0600118075	
455	Control Box	9366299004	9366299004	
464	Cover (Cabinet)	9363400007	9363400007	
514	Control Box Cover	9363201000	9363201000	
568	Rubber Bushing	9357376004	9357376004	
587	Support Plate (Eva.)	9363404005	9363404005	
588-1	Bracket Eva. R	9363199000	9363199000	
588-2	Bracket Eva. L	9363198003	9363198003	
625	Cord Bushing	9359240006	9359240006	
653-1	CUP SCREW	9385089020	9385089020	
734	Panel Top	9363504002	9363504002	
761	Side Panel-R Assy	9363507003	9363507003	
762	Side Panel-L Assy	9363505009	9363505009	
815-1	Terminal 7P	9703403019	9703403019	
875	Filter PCB Assy	9704561251	9704561251	
982-1	Cord Clamp	9356857009	9356857009	
982-2	Cord Clamp-B	9356858006	9356858006	

OUTDOOR UNIT











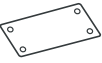
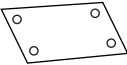

Ref. No.	Description	Part No.	Ord. Q'ty	Ref. No.	Description	Part No.	Ord. Q'ty
		AOY18LMAK2				AOY18LMAK2	
2	Fan Guard	9371187013		335	Accumulator Holder Rubber	9354022010	
4	Emblem	9351355005		343	Solenoid	9900165079	
5	Front Panel	9371924014		344	4-Way Valve	9900163013	
7	Connecteur Cover (Cabinet)	9366398004		345	Joint Pipe (3Way) Assy	9373729129	
12	Base Assy	9371920078		346	Expansion Valve Assy	9373729068	
13-1	3-Way Valve	9372205044		348	Pressure Switch Assy	9373729044	
13-2	2-Way Valve	9372204054		349	Capirally Assy	9373729211	
13-3	3-Way Valve	9372205051		361	Accum Support Assy	9372252017	
14	Valve Cover	9372796016		527	Protective Net	9371934013	
16	Condenser Assy	9372181096		734	Top Panel	9372304013	
26-1	Compressor Cover A	9373730019		---	Gasket (Comp)	9373266013	
26-2	Compressor Cover B	9373730026		---	Washer (Rubber) (Comp)	9358078006	
29	Separate Wall	9372795019		---	Compressor pressure switch	9900186012	
31	Controller PCB Assy	9705285057		---	Compressor thermal switch	9373263012	
33	Control Cover	9372792018		---	Thermistor Valve	9900194017	
39	Propeller Fan Assy	9366378013		---	Thermistor discharge	9704219039	
41	Motor Induct	9601671046		---	Heat exchanger thermistor	9704220059	
45-1	Motor Bracket	9371929019		---	Thermistor outdoor	9703516047	
45-2	Motor Bracket-Top	9371931012		---	Thermistor heat sink	9900195014	
45-3	Motor Bracket-Center	9371930015		---	Special Nut M8 (Comp)	9355091008	
45-4	Motor Bracket-Bottom	9371932019		---	Clip (Cable)	9352715006	
46	Compressor Assy	9373262015		---	Br Sheet	9363708042	
64	Side Panel L	9371926018		---	Relay	9900117016	
65	Side Panel R	9371927015		---	Condenser Sub Assy	9372313121	
85	Valve Plate	9371928036		---	Thermister Holder Pipe	313714262805	
108	Rubber Seat (Comp)	9358080009		---	Capacitor, Plastic	9704305077	
109	Terminal Cover (Comp)	9373264019					
260	Receiver Tank Assy	9373426011					
273	Strainer Assy	9366602019					
334	Accumulator	9368391003					

Inverter Assy

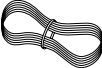

Ref. No.	Description	Part No.	Ord. Q'ty
31	Controller PCB Assy	9705285057	
---	ACTPM	9703457012	
---	Capacitor, Elec	9705387010	
---	Capacitor, Plastic	9704305077	
---	Fuse	0600086039	
---	Terminal 8P	9900203047	
---	Fuse Holder	0501454012	
---	Terminal 2P	9701971015	

STANDARD ACCESSORIES

INDOOR UNIT ACCESSORIES

Name and Shape	Q'ty	Application	Part No.
Installation template 	1	For positioning the indoor unit	ARY9LUAB 9364224008
Installation template 	1	For positioning the indoor unit	ARY12, 14LUAD 9364225005
Hanger 	4	For suspending the indoor unit from ceiling	9363195002
Tapping screw (φ 4 x 10) 	8	For installing the hanger	301171164104
Special nut A (large flange) 	4	For suspending the indoor unit from ceiling	313005446653
Special nut B (small flange) 	4		313005446759
Coupler heat insulation (large) 	1	For indoor side pipe joint (large pipe)	9350716029
Coupler heat insulation (small) 	1	For indoor side pipe joint (small pipe)	9352766015
Binder 	(Small) 1	For remote controller and remote controller cord binding	313361275805
	(Large) 4	For fixing the coupler heat insulation	312300787605
Remote controller 	1	Heat & Cooling model	9372266014
Remote controller cord 	1	For connecting the remote controller	9372714010
Tapping screw (φ 4 x 16) 	2	For installing the remote controller	0700181108
Filter 	3	For installing to indoor unit	9366833017
Drain hose insulation 	1	Insulates the drain hose and vinyl hose connection	313806217708

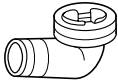
OUTDOOR UNIT ACCESSORIES

Name and Shape	Part No.
Drain pipe 	9303029015
Drain cap 	313166024302
Adapter D (1/2" → 3/8") 12.7mm → 9.52mm 	9370244007



Большая библиотека технической документации
<https://splitsystema48.ru/instrukcii-po-ekspluatacii-kondicionerov.html>
каталоги, инструкции, сервисные мануалы, схемы.